

■ Guiding of model [Incremental type] / 型號索引

Ex : **EMS - 25 D - H - 5M**
1 2 3 4 5

1	Product (產品系列) : 「EMS」 = EMS series (Die-cast Zn) 「EMK」 = EMK series (Intensive ABS)	3	Output method (輸出方式) 「Non」 = NPN+PNP (Push-Pull) 「D」 = Line driver
2	Resolution (解析度) 「1」 = 1 μm ; 「5」 = 5 μm ; 「10」 = 10 μm 「25」 = 25 μm ; 「50」 = 50 μm ; 「100」 = 100 μm 「250」 = 250 μm ; 「500」 = 500 μm ; 「1K」 = 1K μm	4	Max. output frequency (最高輸出頻率) 「H」 = 250 KHz ; 「SH」 = 2000 KHz 「Non」 = 16 KHz
5	Length of lead wire (出線長度) : 「Non」 = 3 m ; 「5M」 = 5 m ; 「10M」 = 10 M		

■ Electrical Specification / 電氣規格

Output model	輸出型式	Push - Pull	Line Driver
Operating voltage	工作電壓	10 ~ 30VDC	5 VDC±10%
Output method	輸出方式	A/B/Z	A/B/Ā/B̄
Ripple of power	電源漣波	10% peak to peak	
Current consumption	耗電流	30 mA max.	
Output current	輸出電流	50mA max. (each)	
Protection circuit	保護回路	Short circuit & polarity reversed	
Voltage drop	輸出壓降	0.8V max.	
Residual voltage	殘餘電壓	0.1V max.	
Leakage current	洩漏電流	0.1mA max.	
Noise resistance	抗干擾	2kv/1μs	
EMC Immunity		ESD : 8 KV Air Discharge (Level3) / EN-61000-4-2 RF Interference : 10V / M / ENV-50140 Burst test : 2KV / EN61000-4-4	
EMC Interference		IEC 61000-6-4	
Dielectric strength	電介強度	2.5kv / 1 minute min.	
Insulation strength	絕緣強度	100 MΩ / 500vdc	
Approval	安規	CE / RoHS	

■ Mechanical Data / 機械規格

Resolution	解析度	1 μm	5 μm	10 μm	25 μm	50 μm	100 μm	250 μm	500 μm	1K μm
Travel speed (m/s)	SH	2000KHz	8.0	25.0	25.0	25.0	25.0	25.0	25.0	25.0
	H	250kHz	1.0	5.0	10.0	25.0	25.0	25.0	25.0	25.0
	Non	16KHz	0.06	0.30	0.60	1.50	3.00	6.00	15.0	25.0
Setting distance	安裝距離	0.1 ~ 4.0 (mm)								
Pole width	磁距	5.0mm								
System accuracy	系統精度	± (0.025 + 0.015 x L) mm, (L = Length of magnetic tape ; Unit : meter)								
Repeat accuracy	重複精度	± 0.01 mm max.								
Measuring length	可量測長度	Infinite (Limitless)								
Vibration resistance	抗振動	300m/ / (55 ~ 2000 Hz) (IEC-60068-2-6)								
Shock resistance	抗衝擊	300m/ with 11ms (IEC-60068-2-27)								
Lead wire	出線方式	5.2Φ shielded cable								
Housing material	外殼材質	EMS : Die-cast Zn ; EMK : Intensive ABS								
Operating circum.	工作環境	-25°C ~ +85°C ; 100%RH max. (Condensation permitted)								
Protection class	保護等級	IP-67 (IEC-60529)								

Output circuit / 輸出回路

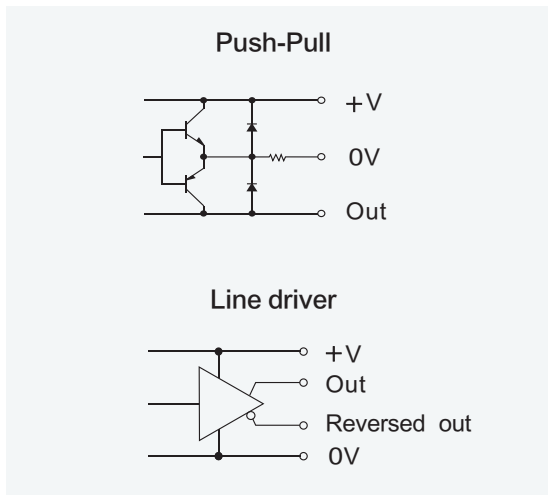

Output timing chart / 輸出時序圖

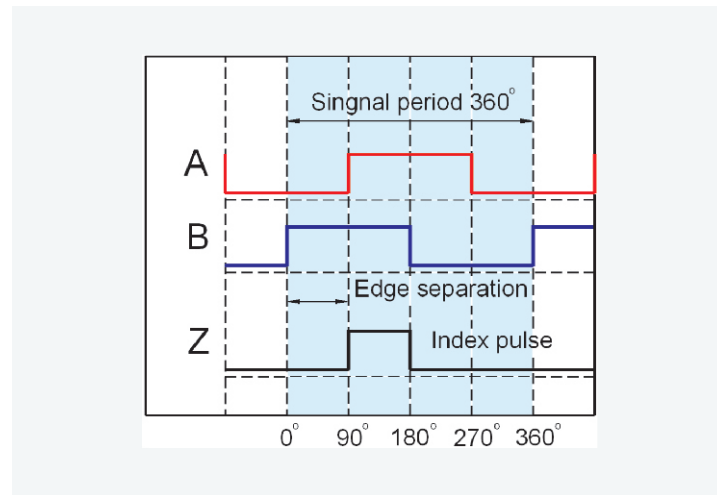

Connections / 接線圖

Push-Pull (推拉式)		
Connector No.	Color	Description
# 1	Brown	+ V (1)
# 3	Blue	0 V (3)
# 4	Black	Phase A (4)
# 2	White	Phase B (2)
# 5	Yellow	Phase Z (5)

Line driver (差動式)			
Color	Description	Color	Description
Brown	+V	Blue	0 V
Black	Phase A	Yellow	Phase \bar{A}
White	Phase B	Grey	Phase \bar{B}

Outline dimension / 外形圖

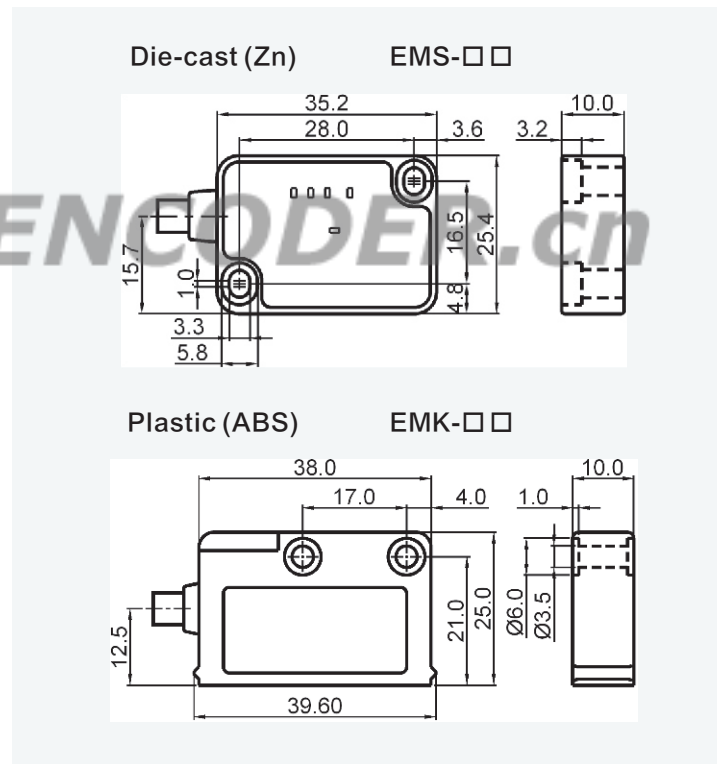

Mounting instruction / 安裝注意事項

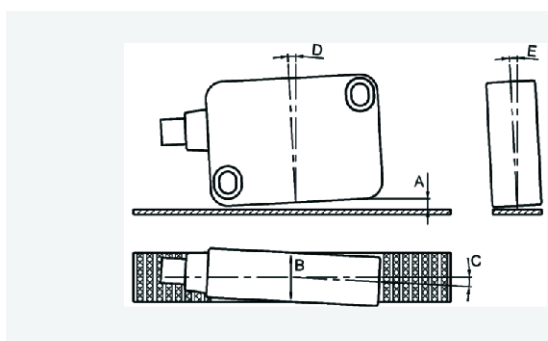

Please ensure the correct alignment of the sensor and magnetic band (see diagram).

- ※ Allowance of tolerances
- A : Setting distance : 4.0mm max.
- B : Lateral offset : ± 2.0 mm max.
- C : Misalignment (Yaw) : $< \pm 3^\circ$ max.
- D : Longitudinal tilt (Pitch) : $< \pm 3^\circ$ max.
- E : Lateral tilt (Roll) : $< \pm 3^\circ$ max.

■ Pilot of status

After the installation of the magnetic scale, the sensor head can be easily adjusted on the machine using the pilot of status (Red LED) .

It is on the best sensing status while the pilot of status (Red LED) is turned off completely.

If the pilot of status (Red LED) has some light that it is not on the best sensing status.

If all LED are turned on that it is on the error sensing status

完成磁條固定後可以很容易依狀態指示燈完成感應頭的安裝。

※狀態指示燈(紅色LED)完全熄滅才是最佳感測狀態。

※狀態指示燈(紅色LED)越亮時感測狀態越差。

※如果所有LED都亮起就是錯誤感測狀態。

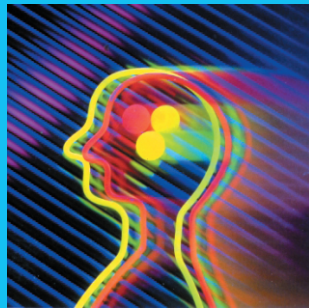

Think Controls

※ 以使用者角度設計『實用耐用的電控產品』

※ 以量產標準化製造『世界標準的電控產品』

※ 以滿足客戶需求追求『企業永續經營』

- ※ On user's position, to develop more 「Performance & Reliable controls」
- ※ By mass-quantity producing, To produce 「World standard controls」
- ※ By satisfying customer's requirements, To manage company foreverly.

FOTEK

陽明電機股份有限公司
FOTEK CONTROLS CO., LTD.

Specification may be modified without notice in advance (2012/11/26)

規格變更恕不事先通知